

HL4M Dri-Prime® Pumps

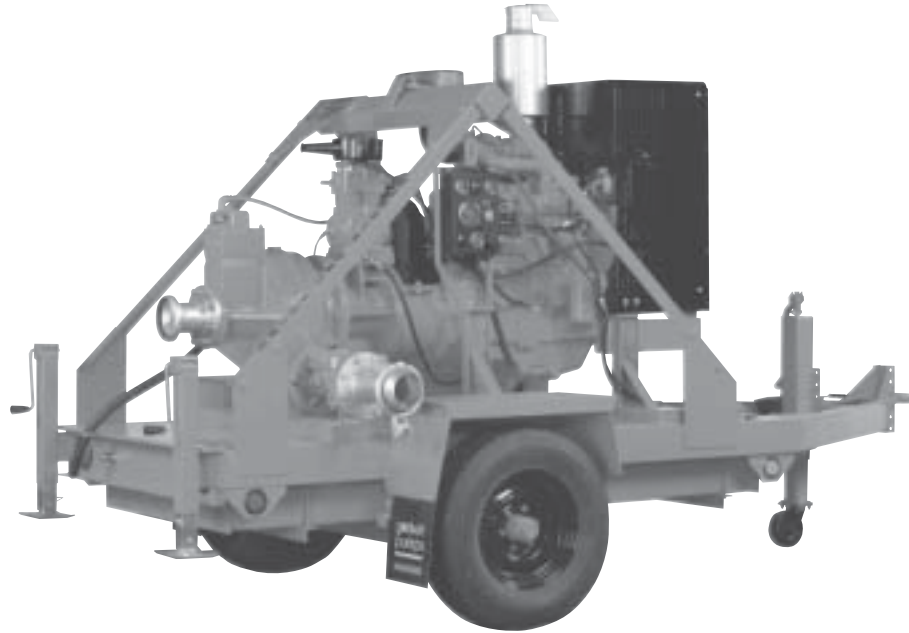

The Godwin Dri-Prime 4" x 4" (100mm x 100mm) HL4M automatic self-priming centrifugal pump is a compact, high pressure pump perfectly suited for temporary pumping under discharge pressure conditions or high discharge lifts. Capable of generating maximum flows of 1,000 gallons per minute (63.1 l/sec.) and discharge heads to 455 feet (138.7M) or 195 psi (13.4 BAR), the HL4M is used in temporary fire service, quarry and mine dewatering, and as a temporary replacement for permanently installed transfer pumps. Like all Godwin Dri-Prime pumps, the HL4M can prime and reprime automatically from dry to 28 feet (8.5M) of suction lift.

Features

- Fully automatic priming from dry to 28 feet (8.5M) of suction lift. Maximum heads to 455 feet (138.7M), maximum flows to 800 gpm (50.5 l/sec.).
- Pumpend available in cast iron, stainless steel and other hardened materials.
- Extensive application flexibility — will handle sludge with solids up to 1-3/8" (35mm) in diameter.
- Continuously operated "Godwin" venturi air ejector priming device featuring direct drive air compressor requiring no periodic adjustment or control.
- Dry running, oil-bath, mechanical seal with high abrasion resistant silicon carbide interfaces.
- Solids handling swing-type Non Return valve with renewable flexible rubber seat.
- Compact unit mounted on a heavy-duty skid base or two-wheeled highway trailer both incorporating integral overnight running fuel tank and lifting frame.
- Simple maintenance — normally limited to checking engine and seal cavity oil levels.
- Standard engine — John Deere 4045T. Available with a variety of engines including Caterpillar and Deutz. Electric motor driven units are also available.
- Low-profile side discharge for easy pipe connection.
- A variety of silenced units are available.

HL4M Performance Curve

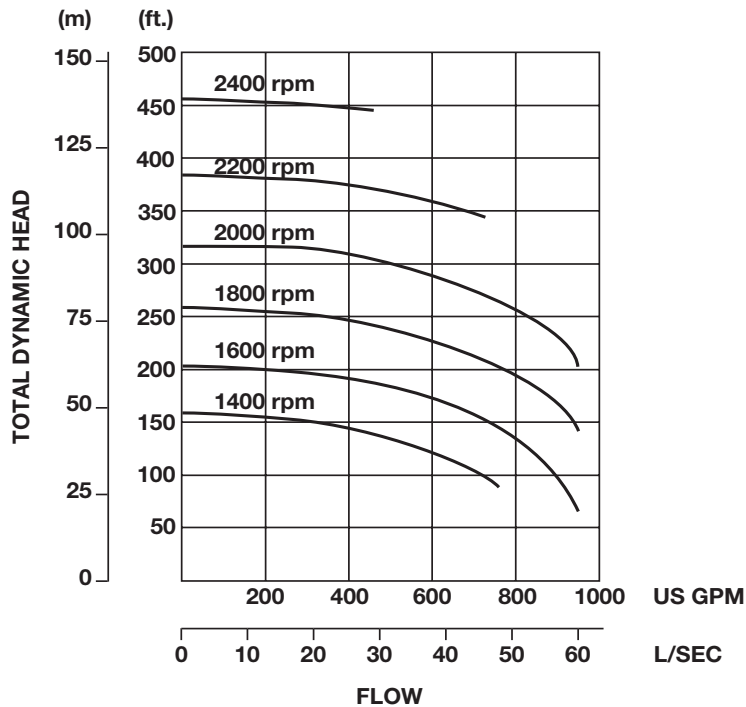

HL4M Performance Table

Diesel Set – John Deere 4045T, 102 hp (76 kw) @ 2400 rpm
Impeller Diameter – 14 9/16 inches (370 mm)

Total Suction Head Feet	Total Delivery Head – Feet				
	150	200	250	300	350
	Output – GPM				
10	1000	995	972	820	640
15	990	983	966	810	620
20	900	872	824	735	550
25	770	760	740	690	480

Performance data listed in table and curves based on water tests at sea level and 68° F (20° C). Larger diameter pipes may be required for maximum flows.

Dimensions

HL4M–John Deere 4045T, Skid Base
 Weight: 4,560 lbs. (2,068 kg.)

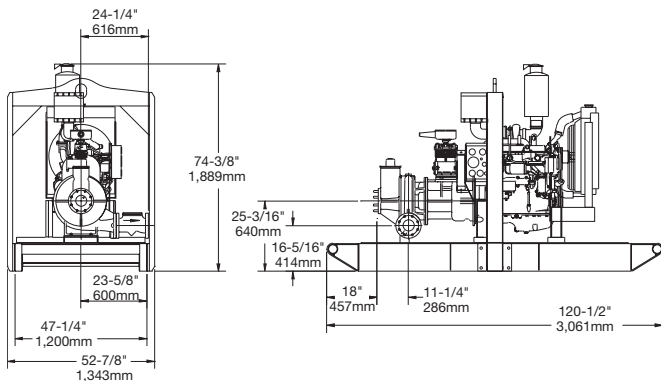

Specifications

- Maximum Operating Speed:** 2400 rpm
- Maximum Operating Temperature:** +212°F (100°C)
- Maximum Working Pressure:** 197 psi (13.6 BAR)
- Maximum Suction Pressure:** 100 psi (6.9 BAR)
- Maximum Casing Pressure:** 296 psi (20.4 BAR)
- Fuel Tank Capacity:** 100 gallons (378.5 liters)
- Fuel Consumption:** 5.2 gph (19.7 lph)
- Pipe Connections:** 4" (100mm) ASA 150#
- Solids Handling:** 1-3/8" (35mm) diameter

Materials

- Pump Casing, Separation Tank and Non Return Casing:** Close-Grained Cast Iron
- Impeller:** Cast Chromium Steel
- Shaft:** 1-1/2% Nickel/Chromium Steel
- Wearplates:** Close Grained Cast Iron (optional 26% Chrome/Iron available)
- Non Return Valve Flapper:** High Nitrile Rubber
- Mechanical Seal Faces:** Solid Silicon Carbide



One Floodgate Road, Bridgeport, NJ 08014, USA
 (856) 467-3636 • Fax: (856) 467-4841
 Quenington, Cirencester, Glos., GL7 5BX, UK
 +44 (0)1285 750271 • Fax: +44 (0)1285 750352

E-mail: sales@godwinpumps.com
 www.godwinpumps.com

BRANCH LOCATIONS:
 Norwich, CT • Buffalo, NY • Chicago, IL
 Washington, DC • Richmond, VA • Virginia Beach, VA
 Charleston, WV • Raleigh, NC • Charlotte, NC
 N. Charleston, SC • Atlanta, GA • Houston, TX
 San Antonio, TX • Helena, MT • Los Angeles, CA

Dri-Prime® and the color orange for pumps are registered trademarks of Godwin Pumps of America, Inc.
 Specifications and illustrations are subject to revision without notice.
 © Copyright 2003 Godwin Pumps of America, Inc. All rights reserved.